

Product Code:

INTRAD RA2-Option 1 Crashrail



Product Description:-

Intrad RA2-Option 1 is a mid level light to medium duty 200mm high PVC-U crashrail system, designed to protect walls and other vulnerable interior surfaces against damage caused by impact and wear. Ideal for use in minor treatment rooms, waiting areas, general corridors, consulting rooms & equipment bays etc.

P20/171 PROPRIETARY 200mm LIGHT DUTY PVC-U CRASHRAIL SYSTEM

Manufacturer:

PJP Ltd., St Albans Road West, Hatfield, Hertfordshire, AL10 0TF.
T: 01707 266 726. F: 01707 263 614
E: sales@intrad.com W: www.intrad.com

Product reference: Intrad RA2-Option 1 Crashrail.

Comprising high impact PVC-U cover section fixed over sprung plastic brackets.

Impact Rating: Light/Medium Duty

Size: 200mm high 30mm deep Crashrail

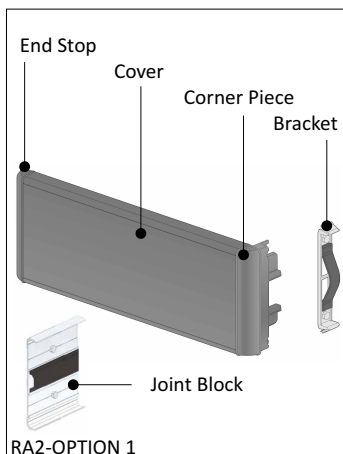
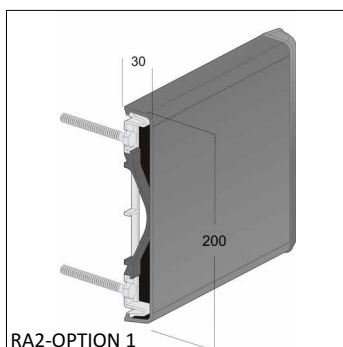

Accessories:

- RA55: End Stop
- RA44: External 90° Bend
- RA4: Fabricated non 90° bend
- RA8: Joint Block

Colour/Finish:

To be selected from the manufacturer's Standard colour range or Artist Range. Smooth easy to clean top and bottom edges with an embossed impact zone on the front face.

Fixing:

In accordance with the manufacturer's instructions. Cover snap fixed over sprung plastic brackets screw fixed at maximum 600mm centres. Jointing: Butt-jointed over an RA8 Joint Block.

Product Code:

INTRAD RA2-Option 2 Crashrail



Product Description:-

Intrad RA2-Option 2 is a mid height medium/heavy duty 200mm PVC-U crashrail system, designed to protect walls and other vulnerable interior surfaces against damage caused by moving equipment.

Intrad RA2-Option2 is ideal for use in major treatment rooms, general corridors, ward corridors, utility rooms, examination rooms & dining rooms etc.

P20/171A PROPRIETARY 200mm MEDIUM DUTY PVC-U CRASHRAIL SYSTEM

Manufacturer:

PJP Ltd., St Albans Road West, Hatfield, Hertfordshire, AL10 0TF.

T: 01707 266 726. F: 01707 263 614

E: sales@intrad.com W: www.intrad.com

Product reference: Intrad RA2-Option 2 Crashrail.

Comprising high impact PVC-U cover section fixed over aluminium brackets and single continuous impact absorber.

Impact Rating: Medium/Heavy Duty

Size: 200mm high 30mm deep Crashrail

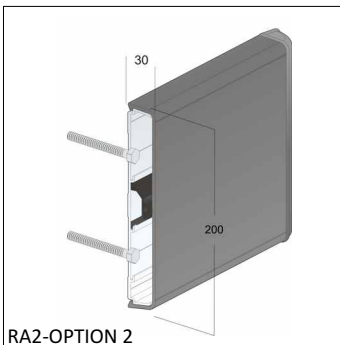

Accessories:

RA55: End Stop

RA44: External 90° Bend

RA4: Fabricated non 90° bend

RA8: Joint Block

Colour/Finish:

To be selected from the manufacturer's Standard colour range or Artist Range. Smooth easy to clean top and bottom edges with an embossed impact zone on the front face.

Fixing:

In accordance with the manufacturer's instructions.

Cover snap fixed over aluminium brackets (screw fixed at maximum 600mm centres) and continuous impact absorber.

Joining: Butt-jointed over an RA8 Joint Block

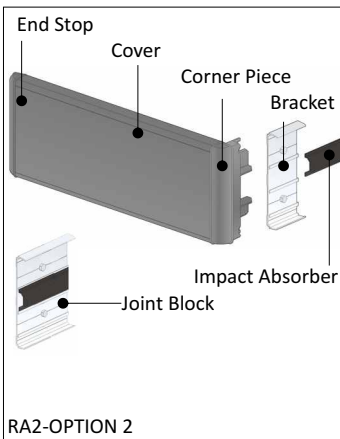

Product Code:

INTRAD RA2-Option 3 Crashrail



Product Description:-

Intrad RA2-Option 3 is a mid level 200mm high heavy duty PVC-U crashrail system, designed to protect walls and other vulnerable interior surfaces against damage caused by impact from trolleys, beds and similar mobile equipment. The continuous aluminium core also increases impact resistance to light weight wall structures.

Intrad RA2-Option 3 is ideal main circulation areas, wheelchair damage, kitchen corridors, trolley stores, staff base & goods in etc.

P20/171B PROPRIETARY 200mm HEAVY DUTY PVC-U CRASHRAIL SYSTEM

Manufacturer:

PJP Ltd., St Albans Road West, Hatfield, Hertfordshire, AL10 0TF.
T: 01707 266 726. F: 01707 263 614
E: sales@intrad.com W: www.intrad.com

Product reference: Intrad RA2-Option 3 Crashrail.

Comprising high impact PVC-U cover section fixed on continuous aluminium core and single impact absorber.

Impact Rating: Heavy Duty

Size: 200mm high 30mm deep Crashrail

Accessories:

- RA55: End Stop
- RA44: External 90° Bend
- RA4: Fabricated non 90° bend

Colour/Finish:

To be selected from the manufacturer's Standard colour range or Artist Range. Smooth easy to clean top and bottom edges with an embossed impact zone on the front face.

Fixing:

In accordance with the manufacturer's instructions.

Cover snap fixed over Continuous aluminium core (fixed at maximum 600mm centres) and impact absorber.

Jointing: Butt-jointed aluminium with offset overlap joints in the cover & impact absorber.

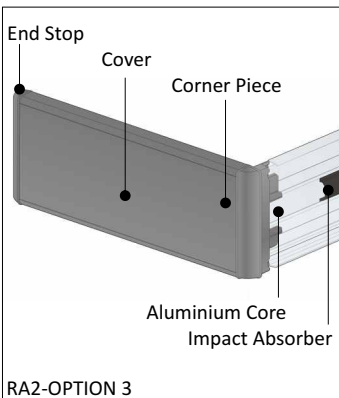
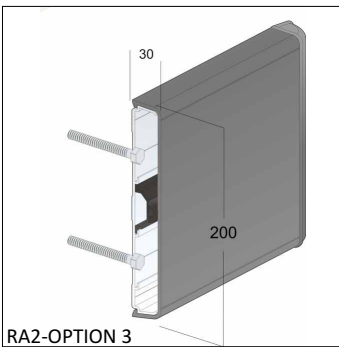

Product Code:

INTRAD RA2-Option 4 Crashrail



Product Description:-

Intrad RA2-Option 4 is a mid height 200mm high Heavy/Severe duty PVC-U crashrail system. The system incorporates three impact absorbers clipped into a continuous aluminium core to offer high levels of impact resistance.

Intrad RA2-Option 4 is ideal for use in main hospital streets, storage areas, lift lobbies, foyers and main entrances etc.

P20/171C PROPRIETARY 200mm SEVERE DUTY PVC-U CRASHRAIL SYSTEM

Manufacturer:

PJP Ltd., St Albans Road West, Hatfield, Hertfordshire, AL10 0TF.

T: 01707 266 726. F: 01707 263 614

E: sales@intrad.com W: www.intrad.com

Product reference: Intrad RA2-Option 4 Crashrail.

Comprising high impact PVC-U cover section snap fixed over continuous aluminium core and three impact absorbers.

Impact Rating: Heavy/Severe Duty

Size: 200mm high 30mm deep Crashrail

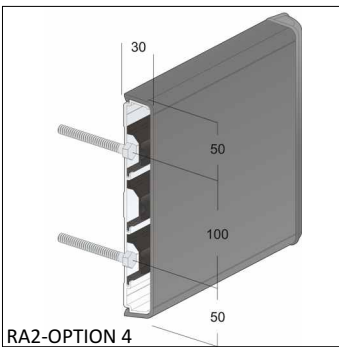

Accessories:

RA55: End Stop

RA44: External 90° Bend

RA4: Fabricated non 90° bend

Colour/Finish:

To be selected from the manufacturer's Standard colour range or Artist Range. Smooth easy to clean top and bottom edges with an embossed impact zone on the front face.

Fixing:

In accordance with the manufacturer's instructions.

Cover snap fixed over Continuous aluminium core (fixed at maximum 600mm centres) and three impact absorbers.

Jointing: Butt-jointed aluminium with offset overlap joints in the cover & impact absorbers.

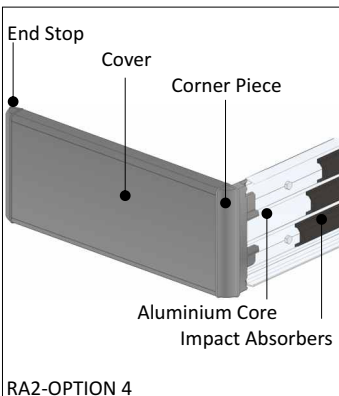

Product Code:

INTRAD RA2-Option 5 Crashrail



Product Description:-

Intrad RA2-Option 5 is a mid height heavy duty 200mm PVC-U guardrail system with extra projection, designed to protect walls and other vulnerable interior surfaces against damage where there is a requirement for extra wall clearance.

Intrad RA2-Option 5 is ideal for use in circulation areas, wheelchair damage, kitchen corridors, trolley stores, staff base & goods in etc.

P20/171D PROPRIETARY 200mm HEAVY DUTY PVC-U CRASHRAIL SYSTEM

Manufacturer:

PJP Ltd., St Albans Road West, Hatfield, Hertfordshire, AL10 0TF.

T: 01707 266 726. F: 01707 263 614

E: sales@intrad.com W: www.intrad.com

Product reference: Intrad RA2-Option 5 Crashrail.

Comprising high impact PVC-U cover section fixed over continuous aluminium core and impact absorber and projecting 45mm from the wall on mounting cushions.

Impact Rating: Heavy Duty

Size: 200mm high 30mm deep Crashrail on 45mm mounting cushions.

Accessories:

RA55: End Stop

RA44: External 90° Bend

RA4: Fabricated non 90° bend

Colour/Finish:

To be selected from the manufacturer's Standard colour range or Artist Range. Smooth easy to clean top and bottom edges with an embossed impact zone on the front face.

Fixing:

In accordance with the manufacturer's instructions.

Continuous aluminium core screw fixed at maximum 600mm centres, through pairs of mounting cushions.

Jointing: Butt-jointed aluminium with offset overlap joints in the cover

Substrates:-

If the INTRAD RA2-Option 5 is to be fitted to hollow walls (single/double skin plasterboard systems or similar) a suitable continuous noggins, pattress or metal channel must be installed.

